



PT. DELTA ANUGRAH
GENERAL SUPPLIER

Product Catalogue



We Supply All Your Need

RESISTANCE WELDING MACHINE

■ AC WELDING MACHINES



Si Type



SPi Type



P Type

■ SEAM WELDER



SC Type

■ INVERTER POWER SUPPLY



WIP2 Type

■ PORTABLE WELDER



G1 Type

■ CONDENSER TABLE TYPE



CSTi Type

■ WELDER CONTROLLER



CK3-8-15

■ WELDING CURRENT MONITOR



CE1-6-4



WM-3VP

SPOT and PROJECTION WELDER

RESISTANCE WELDING MACHINES

AC/DC INVERTER WELDING MACHINES



S1 Type



SP1 Type



P Type



SC Type

INVERTER POWER SUPPLY



WIP2 Type

PORTABLE WELDER



G1 Type

FLASH BUTT WELDER

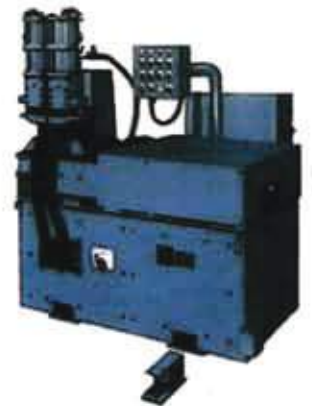

FA-10-25S

WELD CONTROL



MODEL : CK3-8-15js3



MODEL : CE1-6-4js3

WELDER CURRENT METER



MODEL : WM-5

STATIONARY SPOT WELDING

SINGLE - PHASE
AC SPOT WELDING MACHINE



NUT FEEDER



NUT FEEDER



Seam and Portable Welder Parts



"C" type Transformer Gun

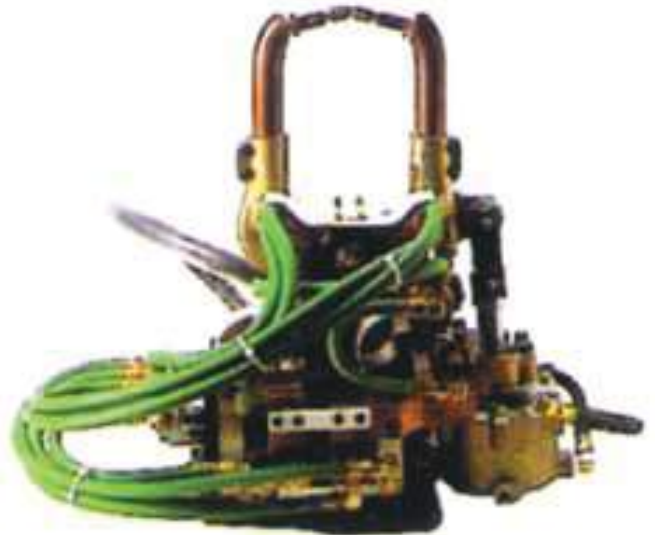

"X" type Transformer Gun



"C" type Transformer Gun

SEAM and PORTABLE WELDER PARTS

Portable Guns

"C" type



"X" type



Accessories

Arm Tip Base



Electrode



Gun Hungry & Hand Switch

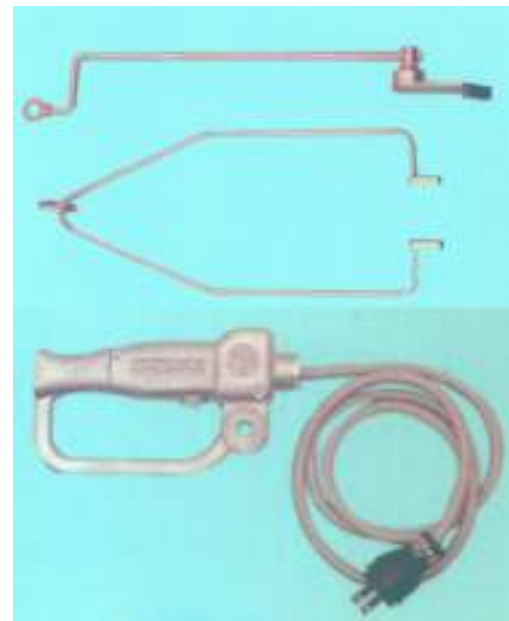

Air Water - Cooled Cable



Low Reactance Cable



Low-Reactance Cable for Spot Welding Machine (4LK)

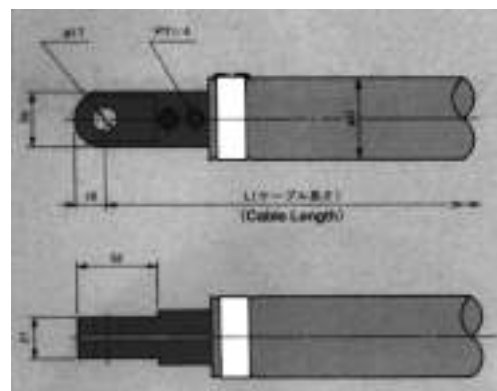

QUICK COUPLING

PLUG

PH for Hose Connection

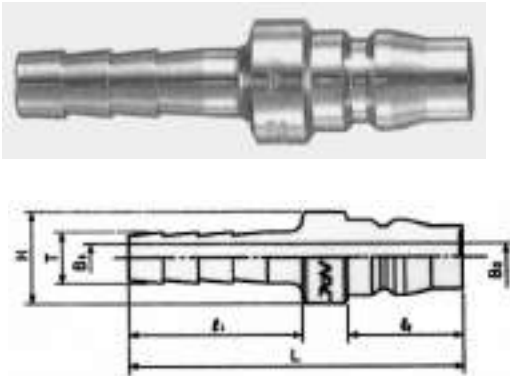

Type	Model	Application	Weight(g)			Dimension(mm)						
			Steel	Brass	Stainless	L	φ H	φ 1	φ 2	φ T	φ B1	φ B2
20	CAL21PH	1/8" Hose	26	—	—	58	16	30	20	7.5	4.5	7.5
	CAL22PH	1/4" Hose	30	30	28	58	16	30	20	9	5	7.5
	CAL23PH	3/8" Hose	33	33	30	62	16	34	20	11.3	7.5	7.5
	CAL24PH	1/2" Hose	60	63	58	64	20	36	20	15	7.5	7.5
40	CAL44PH	1/2" Hose	69	73	63	67	22	36	23	15	9	13
	CAL46PH	3/4" Hose	120	137	116	76	30	45	23	21	13	13
	CAL48PH	1" Hose	155	188	158	86	34	55	23	27	20	13

PM for Female Thread Connection



Type	Model	Application	Weight(g)			Dimension(mm)						
			Steel	Brass	Stainless	L	Hex	φ 1	φ 2	T	φ B1	φ B2
20	CAL21PM	Rc 1/8"	24	25	23	39	14	11	20	R 1/8"	4	7.5
	CAL22PM	Rc 1/4"	26	29	26	42	14	13	20	R 1/4"	7.5	7.5
	CAL23PM	Rc 3/8"	44	48	44	43	19	14	20	R 3/8"	7.5	7.5
	CAL24PM	Rc 1/2"	60	66	54	46	22	16	20	R 1/2"	12	7.5
40	CAL44PM	Rc 1/2"	62	76	69	47	22	16	23	R 1/2"	13	13
	CAL46PM	Rc 3/4"	92	124	107	49	32	18	23	R 3/4"	19	13
	CAL48PM	Rc 1"	140	200	177	53	35	22	23	R 1"	22	13

PF for Female Thread Connection

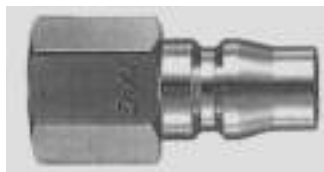

Type	Model	Application	Weight(g)			Dimension(mm)					
			Steel	Brass	Stainless	L	Hex	φ 1	φ 2	T	φ B
20	CAL21PF	R 1/8"	22	—	—	33	14	11.5	20	Rc 1/8"	7.5
	CAL22PF	R 1/4"	30	32	31	37	17	13	20	Rc 1/4"	7.5
	CAL23PF	R 3/8"	40	43	39	38	21	14	20	Rc 3/8"	7.5
	CAL24PF	R 1/2"	81	79	69	39	29	15	20	Rc 1/2"	7.5
40	CAL44PF	R 1/2"	85	89	71	41	29	15	23	Rc 1/2"	13
	CAL46PF	R 3/4"	117	129	95	43	35	17	23	Rc 3/4"	13
	CAL48PF	R 1"	191	210	133	51	41	22	23	Rc 1"	13

QUICK COUPLING

Socket

SH for Hose Connection

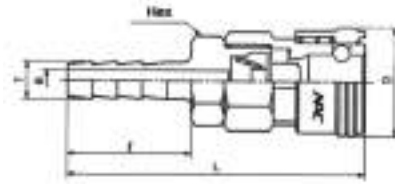

Type	Model	Application	Weight (g)			Dimension(mm)					
			Steel	Brass	Stainless	L	φ D	Hex	ℓ	φ B	φ T
20	CAL21SH	1/8" Hose	99	—	—	72.5	26.5	19	30	4.5	7.5
	CAL22SH	1/4" Hose	102	111	102	72.5	26.5	19	30	5	9
	CAL23SH	3/8" Hose	105	112	105	76.5	26.5	19	34	7.5	11.3
	CAL24SH	1/2" Hose	117	127	125	78.5	26.5	19	36	9	15
40	CAL44SH	1/2" Hose	234	235	213	84	36.5	29	36	9	15
	CAL46SH	3/4" Hose	266	259	239	93	36.5	29	45	13	21
	CAL48SH	1" Hose	287	293	292	103	36.5	29	55	20	27

SM for Female thread Connection



Type	Model	Application	Weight (g)			Dimension(mm)					
			Steel	Brass	Stainless	L	φ D	Hex	ℓ	φ B	T
20	CAL21SM	Rc 1/8"	98	—	—	53.5	26.5	19	11	4	R 1/8"
	CAL22SM	Rc 1/4"	100	110	101	55.5	26.5	19	13	7	R 1/4"
	CAL23SM	Rc 3/8"	108	117	107	56.5	26.5	19	14	8	R 3/8"
	CAL24SM	Rc 1/2"	126	140	124	58.5	26.5	22	16	9	R 1/2"
40	CAL44SM	Rc 1/2"	224	227	207	64	36.5	29	16	13	R 1/2"
	CAL46SM	Rc 3/4"	248	261	227	66	36.5	32	18	16	R 3/4"
	CAL48SM	Rc 1"	290	315	272	70	36.5	36	22	22	R 1"

SF for Male Thread Connection

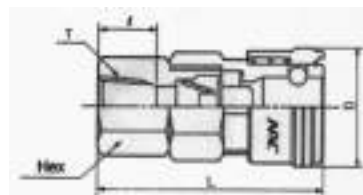

Type	Model	Application	Weight (g)			Dimension(mm)				
			Steel	Brass	Stainless	L	φ D	Hex	ℓ	T
20	CAL21SF	R 1/8"	100	—	—	47.5	26.5	19	11.5	Rc 1/8"
	CAL22SF	R 1/4"	101	108	99	50.5	26.5	19	13	Rc 1/4"
	CAL23SF	R 3/8"	102	109	100	50.5	26.5	21	14	Rc 3/8"
	CAL24SF	R 1/2"	138	153	138	52.5	26.5	29	15	Rc 1/2"
40	CAL44SF	R 1/2"	229	231	212	58	36.5	29	15	Rc 1/2"
	CAL46SF	R 3/4"	263	278	230	60	36.5	35	17	Rc 3/4"
	CAL48SF	R 1"	325	350	278	67	36.5	41	22	Rc 1"

WELDING MONITOR

Cap Tip



Straight Shank

Band Shank



Straight Electrode



Straight Electrode

Shunt



WELDING MONITOR

Swiel Head



Electrode Adaptor



Raw Material Wheel



KCF Sleeve/ Electrode



Straight Holder



L Holder



Order According to Drawing





Semi-Automatic Torches
TIG Torches
Air-Cooled Robotic Torches
Water-Cooled Robotic Torches
Automatic Torches
Automatic TIG Torches
Robotic Peripherals
Fume Extractors
Plasma Laser Parts, Optics



Semi-Automatic Torches



Air-Cooled Robotic Torches



Water-Cooled Robotic Torches



TIG Torches



Replacement Parts



Fume Extractors



Plasma-Laser



Optics

FUME EXTRACTORS

WELDING FUME COLLECTOR



WF-800

WF-801



WF-180



WF-120

Eliminate the hazardous welding fume at welding point. Recommended to be used with a fume extractor torch.

Type	WF-800/801	WF-900/901	WF-300
Rated Input Voltage	200V (3 phase)	200V (3 phase)	200V (3 phase)
Motor Power	2.3kW	3.8kW	0.75kW
Maximum Air Flow	33m ³ /min	55m ³ /min	8m ³ /min
Maximum Pressure	2.65kpa	3.43kpa	2.16kpa
Filter	3	5	1
Noise Level	68dB(A)	73dB(A)	75dB(A)
Weight	200kg	250kg	64kg
Dimensions	H1,645×W767×L730(mm)	H1,740×W900×L880(mm)	H1,060×W490×L600(mm)

Type	WF-180	WF-120
Rated Input Voltage	200V (3 phase)	200V
Maximum Air Flow	3.1m ³ /min	3.0m ³ /min
Maximum Pressure	23.5kpa	21.6kpa
Rated Current	5.0A	5.3A
Maximum Output	1,000W	1,000W
Filter	1	Small Filter × 1
Noise Level	75dB(A)	75dB(A)
Weight	80kg	30kg
Dimensions	H1,000×W360×L660(mm)	H550×W300×L583(mm)

Seam and Portable Welder Parts



Electrode Shaft



Seam Head Knurl

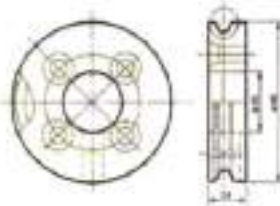

Seam Head Brush



Taper Gauge



Shunt

Kickless and AID/CABLE for Portable Spot Welding Machines



WELDING MONITOR

ACCESSORIES and WELDING TRANSFORMER

► Sky Feeder

The Newly developed "Nut for correct nut selection supply stabilization Rolling Selection" system is used



► Nut Feeder

Nut Feeder meets the reliability and performance needs of customers and employs an electromagnetics absorption supply system so that the supply angle doesn't matter for auto-supply nut stabilization.



► Weld Checker

To check the output current of resistance welder



► Force Gauge

To check the electrode force resistance welder

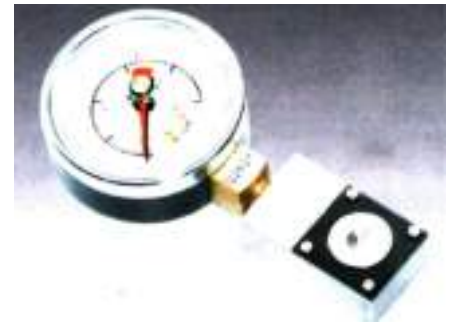

► Epoxy Type welding Transformer

Model : DWL 2
200KVA - 300KVA



Model : DWB 2
100KVA - 300KVA



► AC Welding Transformer

Model : DWL - 11-750
75KVA - 100KVA

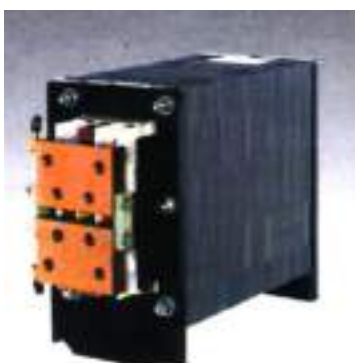

Model : DWL - 11-750
75KVA - 100KVA



STATIONARY SPOT WELDING



SEMI AUTOMATIC TORCHES



[CO₂/MAG Welding Torches]

- **CS Series**
- **CS-35 • α-500W**



Replacement Parts



TIG Welding Torches



Air-Cooled Robotic Torches



Fume Extractors



Water-Cooled Robotic Torches



Contact Tip

WELDING MONITOR

Ti Opener



Tip Remover



Tip Dresser

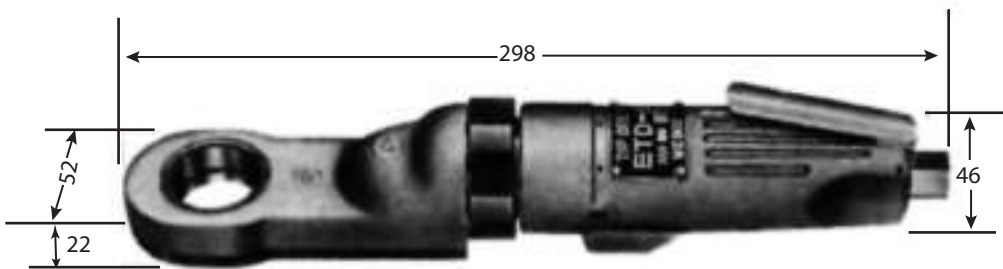
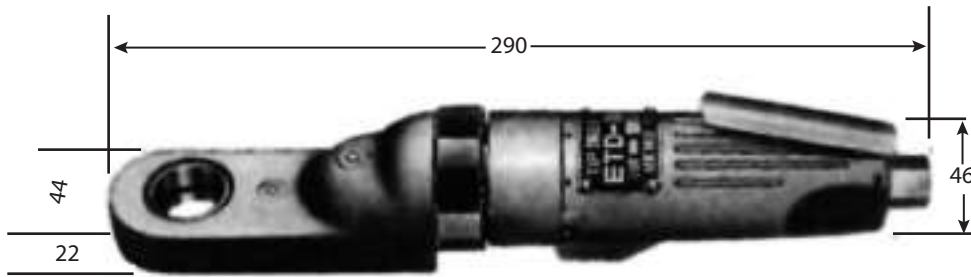

Tip Dresser Attach



PLASMA • LASER • OPTICS

PLASMA / LASER PARTS



OPTICS



REPLACEMENT PARTS

Various Selections for Customers' Needs



TEACHING TIP



BUTT WELDER



SQUARE DRIVE SOCKETS



DRIVER SOCKETS & BITS

- Driver Sockets (Single Hex)
- Driver Sockets (Double Hex)
- Universal Driver Sockets (single Hex)
- Driver Adapters
- Bit Extension Bar
- Slotted Bits
- Driver Bits (Single)
- Turn Down Bits



TORX

- 1/4" TORX Sockets
- 3/8" TORX Sockets
- 1/2" TORX Sockets
- TORX Internal Driver Bits
- TORX Tamper Resistant-Driver Bits
- TORX External Driver-Sockets for Bolts
- Magnetic Screw Holder
- Special Parts

MAGNETIC SOCKETS

Sockets with Fixed Magnet are Designet for use of Bolt only.

Distributed by:



PT. DELTA ANUGRAH
GENERAL SUPPLIER

